



Technical Data Sheet

M22 (L)

» Oil service

M22 (L) VE

» Water service

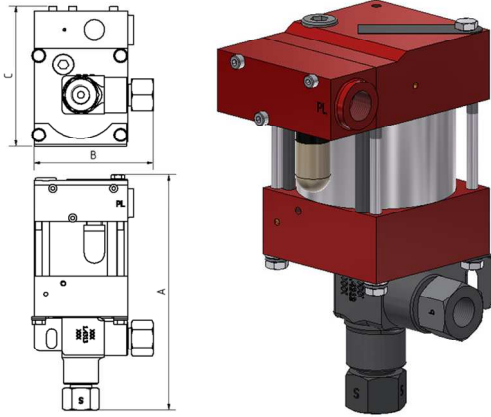

M22 (L)
single acting, single air drive head

Technical Data:

Air drive pressure: 1 - 10 bar / 14.5 - 145 psi

Calculated working pressure: 280 bar / 4060 psi

Pressure ratio: 1:28

Displacement volume/double stroke: 4.6 cm³ / 0.28 cu.inch

Connections:

Inlet: Standard: Bottom Inlet 3/8" BSP

Outlet: 3/8" BSP

Air drive: 3/8" BSP

Maximum operating temperature: 60°C

Net weight: 2.8 kg

Pressure and flow performances, please see enclosed graph.

Wetted materials of construction:

Seal package: M22(L): Polyurethane

M22(L)VE: UHMWPE, FKM

Pump Body: 1.4313

Piston: 1.4112

Fittings: 1.4104

Approximate Dimensions:

A: 201 mm

B: 102 mm

C: 120 mm

Available Options:

Seal material for oil service: M22(L)

Seal material for water service: M22(L)VE

Side inlet: M22(L)S/ M22(L)VES

Hand lever/ Spring return: M22-HL
(only available with seal package Polyurethane, NBR)

External pilot port modification: M22(L)-DIR

Special inlet and outlet ports, i.e. NPT: M22(L)-NPT

M22(L)VE-NPT

Special seal material to handle special fluids on request.

Available Accessories:

Air control units for M series with filter pressure regulator, control pressure gauge and shut off valve: M22(L) with C1

To protect the pump against excessive outlet pressures or to limit the outlet pressure, a safety valve M22(L) with C1/SV-air (The required outlet pressure has to be indicated.) can be fitted to the air control unit in the air drive line.

Please consult factory for more information. All technical and dimensional information subject to change. All General Terms and Conditions of sale, including limitations of our liability, apply to all products and services sold.

Technical Data Sheet

MO22

» Oil service

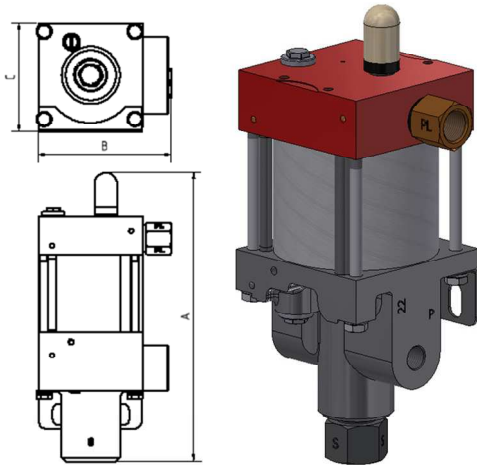

MO22
(Standard= Bottom inlet)

Technical Data:

Air drive pressure:	1-10 bar / 14.5 - 145 psi
Calculated working pressure:	290 bar / 4205 psi
Pressure ratio:	1:29
Displacement volume/double stroke:	4.6 cm ³ / 0.28 cu.inch

Connections:

Inlet:	Standard: Bottom Inlet 3/8" BSP
Outlet:	1/4" BSP
Air drive:	3/8" BSP
Maximum operating temperature:	60°C
Net weight:	3.0 kg

Pressure and flow performances, please see enclosed graph.

Wetted materials of construction:

Top cap:	3.1645
Air cylinder:	3.3206
Seal package:	Polyurethane, NBR
Pump Body:	0.7050
Piston:	1.4112

Approximate Dimensions:

A:	227.5 mm
B:	103 mm
C:	85 mm

Available Options:

Side inlet:	MO22S
External pilot port modification:	MO22-DIR
Special inlet and outlet ports, i.e. NPT:	MO22-NPT
Special seal material to handle special fluids on request.	

Available Accessories:

Air control units with filter pressure regulator, control pressure gauge and shut off valve:	MO22 with C1
To protect the pump against excessive outlet pressures or to limit the outlet pressure, a safety valve can be fitted to the air control unit in the air drive line.	MO22 with C1/SV-air (The required outlet pressure has to be indicated.)

Please consult factory for more information. All technical and dimensional information subject to change. All General Terms and Conditions of sale, including limitations of our liability, apply to all products and services sold.

Technical Data Sheet

MSF22(L)

» Special liquids

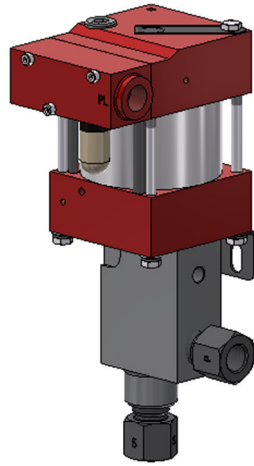
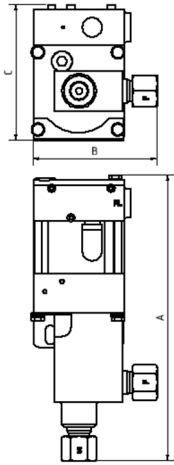

MSF22(L)

single acting, single air drive head and distance piece
(Standard= Bottom inlet)

Technical Data:

Air drive pressure:	1 - 10 bar / 14.5 - 145 psi
Calculated working pressure:	280 bar / 4060 psi
Pressure ratio:	1:28
Displacement volume/double stroke:	4.6 cm ³ / 0.28 cu.inch

Connections:

Inlet:	Standard: Bottom Inlet 3/8" BSP
Outlet:	3/8" BSP
Air drive:	3/8" BSP
Maximum operating temperature:	60°C
Net weight:	3.5 kg

Pressure and flow performances, please see enclosed graph.

Wetted materials of construction:

Seal package:	MSF22(L): PTFE, FKM
Pump Body:	1.4404
Piston:	1.4112
Fittings:	1.4404

Approximate Dimensions:

A:	252 mm
B:	120 mm
C:	108 mm

Available Options:

Side inlet:	MSF22(L)S
Special inlet and outlet ports, i.e. NPT:	MSF22(L)-NPT
Special seal material to handle special fluids on request.	

Available Accessories:

Air control units with filter pressure regulator, control pressure gauge and shut off valve:	MSF22(L) with C1
To protect the pump against excessive outlet pressures or to limit the outlet pressure, a safety valve can be fitted to the air control unit in the air drive line.	MSF22(L) with C1 / SV-air (The required outlet pressure has to be indicated.)

Please consult factory for more information. All technical and dimensional information subject to change. All General Terms and Conditions of sale, including limitations of our liability, apply to all products and services sold.



Leistungsdiagramm/Performance Graph M(O)(SF) 22

Prüfflüssigkeit/Test Liquid: Wasser-Öl-Emulsion/Water Oil Emulsion ca. 1 - 10 cst

